

NOTICE TO BID

The Board of Tillman County Commissioners is accepting sealed bids for the **GRANDFIELD PUBLIC SCHOOLS PARKING PROJECT** until **4:00 p.m. on Friday, May 1, 2026**. Sealed Bids shall be delivered or mailed to the Purchasing Agent located in the Tillman County Clerk's Office, Tillman County Courthouse, P.O. Box 992, 201 N. Main, Frederick, OK 73542. Bids received after 4:00 p.m., CST, May 1, 2026 shall not be considered and shall be returned unopened to the bidder. The sealed envelope containing the bid must be clearly marked **BID #1-2026, Grandfield Schools Project** with the name of the project, opening date and must state Bidders name & address. SEALED BIDS will be opened at 10:00 am on **Monday, May 4, 2026** in the County Commissioners' Office located on the second floor of the Tillman County Courthouse.

A Bid Book containing the Invitation to Bid, Instruction to Bidders, Bid Form, Plans and other related Bid Documents may be examined or picked up at the Tillman County Clerk's Office located on the second floor of the Tillman County Courthouse, 201 N. Main, Frederick, OK 73542.

An original cashier's check, a certified check or a surety bond in the amount of five percent (5%) of the Bid shall accompany the sealed bid for each bidder. In addition to the 5% Bid Bond, a signed Affidavit for Filing with Competitive Bid (Non-Collusion Affidavit) and a Business Relationship Affidavit is required when submitting bids. A 100% Performance Bond, 100% Statutory Bond, 100% One Year Warranty Bond and Proof of Public Liability and Workers Comp Insurance will be required of the successful Bidder. Bonding companies must appear on Treasury Circular 570 and be authorized to transact business in the State of Oklahoma for an amount in excess of the bid. The contract will be awarded to the lowest responsible bidder within 30 days from date of bid opening. Provided, the County may extend the date for awarding the contract for 15 days according to state law (90 days if funds utilized for the project are furnished by an agency of the United States Government).

A site meeting will be held on location at Grandfield Public Schools on Monday, April 20, 2026 at 1:00 P.M.

The Board of Tillman County Commissioners reserves the right to accept or reject any or all bids and waive any informalities. The Board of Tillman County Commissioners also reserves the right to make awards by items, groups of items, or all or none, whichever is in the best interest of the county.

Cacy Caldwell
Tillman County Clerk and Purchasing Agent

BID BOOK

**BID #1-2026
GRANDFIELD PUBLIC SCHOOLS
PARKING LOTS PROJECT
IN DISTRICT #3, TILLMAN COUNTY, OKLAHOMA**

Bids are due by 4:00 pm, Friday, May 1, 2026

**Commissioner Levi Krasser
Tillman County District #3
580-479-5236**

**Attn: Cacy Caldwell, Purchasing Agent Tillman
County Clerk's Office
P.O. Box 992, 201 N. Main
Frederick, OK 73542
580-335-3421 ext. 3**

TABLE OF CONTENTS

BID BOOK:

Page 1	INVITATION TO BID
Pages 2-5	INSTRUCTION TO BIDDERS
Pages 6-10	BID FORM
Page 11	AFFIDAVIT FOR FILING WITH COMPETITIVE BID
Page 12	BUSINESS RELATIONSHIP AFFIDAVIT
Page 13	W-9 FORM

PLANS:

Sheet 1	TITLE SHEET
Sheet 2	TYPICAL SECTION, DETAILS, QUANTITY & NOTES
Sheet 3-7	PLAN VIEW

INVITATION TO BID

SEALED BIDS will be received by the Tillman County Purchasing Agent, on behalf of the Board of County Commissioners, Tillman County, Oklahoma (herein called the "OWNER"), for the

GRANDFIELD PUBLIC SCHOOLS PARKING LOTS PROJECT IN DISTRICT #3, TILMAN COUNTY, OKLAHOMA

until **4:00 p.m. on Friday, May 1, 2026** Sealed Bids shall be delivered or mailed to the Purchasing Department located in the Tillman County Clerk's Office, Tillman County Courthouse, P.O. Box 992, 201 N. Main, Frederick, OK 73542. Bids received after 4:00 p.m., CST, May 1, 2026, shall not be considered and shall be returned unopened to the bidder. The sealed envelope containing the bid must be clearly marked BID #1-2026, Grandfield Schools Project with the name of the project, opening date and must state Bidders name & address.

SEALED BIDS will be opened at 10:00 am on **Monday, May 4, 2026** in the County Commissioners' Office located on the second floor of the Tillman County Courthouse.

A Bid Book containing the Invitation to Bid, Instruction to Bidders, Bid Form, Plans and other related Bid Documents may be examined or picked up at the Tillman County Clerk's Office located on the second floor of the Tillman County Courthouse, 201 N. Main, Frederick, OK 73542.

An original cashier's check, a certified check or a surety bond in the amount of five percent (5%) of the Bid shall accompany the sealed bid for each bidder. In addition to the 5% Bid Bond, a signed Affidavit for Filing with Competitive Bid (Non-Collusion Affidavit) and a Business Relationship Affidavit is required when submitting bids. A 100% Performance Bond, 100% Statutory Bond, 100% One Year Warranty Bond and Proof of Public Liability and Workers Comp Insurance will be required of the successful Bidder. Bonding companies must appear on Treasury Circular 570 and be authorized to transact business in the State of Oklahoma for an amount in excess of the bid.

The contract will be awarded to the lowest responsible bidder within 30 days from date of bid opening. Provided, the County may extend the date for awarding the contract for 15 days according to state law (90 days if funds utilized for the project are furnished by an agency of the United States Government).

The successful bidder and the County must execute a contract embodying the terms of the bid documents, within 60 days from the date the contract was awarded.

No bidder shall obtain a property right in a contract until the contract has been fully executed by both parties.

All matters concerning the contract and project are subject to the provisions of state law and federal law when applicable.

A site meeting will be held on location at Grandfield Public Schools on Monday, April 20, 2026 at 1:00 P.M.

The Board of Tillman County Commissioners reserves the right to accept or reject any or all bids and waive any informalities. The Board of Tillman County Commissioners also reserves the right to make awards by items, groups of items, or all or none, whichever is in the best interest of the county.

Dated: April 13, 2026

Cacy Caldwell
County Clerk and Purchasing Agent

INSTRUCTION TO BIDDERS

SEALED BIDS will be received by the Tillman County Purchasing Agent for the Board of County Commissioners, Tillman County, Oklahoma (herein called the "County"), for the **GRANDFIELD PUBLIC SCHOOLS PARKING LOTS PROJECT IN DISTRICT #3, TILLMAN COUNTY, OKLAHOMA until 4:00 p.m. CST, on Friday, May 1, 2026.** Bids received after 4:00 p.m., CST, May 1, 2026 shall not be considered and shall be returned unopened to the bidder.

SEALED BIDS will be opened at 10:00 am on Monday, May 4, 2026 in the County Commissioners' Office located on the second floor of the Tillman County Courthouse, 201 N. Main, Frederick, OK 73542.

Each BID must be submitted in a sealed envelope, one bid per envelope, and delivered either in person or by mail to the County Clerk's Office, Tillman County Courthouse, P.O. Box 992, 201 N. Main, Frederick, OK 73542. The envelope should bear on the outside the BIDDER'S name, address, closing date and reference **Bid #1-2026, Grandfield Schools Project.**

All bids must be made on the required bid form. All blank spaces must be legibly written in with ink or typewritten and must be fully completed and executed when submitted. Corrections or erasures should be initialed by person completing the bid. The bid documents must be original with original signatures and seals.

The Tillman County Board of Commissioners reserves the right to award or reject any or all bids and waive any informalities. The Board also reserves the right to accept all or part of any bid offered and to accept that bid or part of that bid which will, in the Board's opinion, best serve the public interest. No BIDDER may withdraw a BID within 60 days after the actual date of the opening thereof. Should there be reasons why the contract cannot be awarded within the specified period; the County may extend the date for awarding the contract for 15 days according to state law (90 days if funds utilized for the project are furnished by an agency of the United States Government). Conditional Bids will not be accepted.

Before submitting a BID, BIDDERS should carefully examine the specifications, visit the site of work, fully inform themselves as to the existing conditions and limitations and shall include in the BID a sum to cover the cost of all items included in the Contract. The failure or omission of any BIDDER to do any of the foregoing shall in no way relieve the BIDDER from any obligation in respect to the BID. Extra payments will not be authorized for work that could have been foreseen by a careful examination of the site. Submission of a BID shall constitute acceptance by the BIDDER of existing site conditions as a part of the requirements for this work.

Unit prices will be guaranteed correct by the Bidder and Bid prices are to remain firm.

All applicable laws, ordinances and the rules and regulations of all authorities having jurisdiction over construction of the PROJECT shall apply to the contract throughout. Contractor will also need to comply with the requirements of the D. Davis-Bacon Act.

The CONTRACT DOCUMENTS contain the provisions required for the construction project. Information obtained from an officer, agent, or employee of the COUNTY or any other person shall not affect the risks or obligations assumed by the CONTRACTOR or relieve the CONTRACTOR from fulfilling any of the conditions of the contract.

Each BID must be accompanied by an original Cashier's Check, a Certified Check or Bid Bond in the amount of five percent (5%) of the TOTAL BID as a guarantee of good faith. The check is to be drawn on an Oklahoma bank and made payable to the BOARD OF TILLMAN COUNTY COMMISSIONERS. The BID BOND of the successful BIDDER will be retained until the CONTRACT, PERFORMANCE BOND, STATUTORY BOND and MAINTENANCE BOND have been executed and approved AND PROOF OF PUBLIC LIABILITY AND WORKERS COMP INSURANCE have been provided and approved. The Purchasing Dept, upon receipt of a written notice from the Successful Bidder, will return to them the 5% BID BOND. Checks of unsuccessful bidders will be returned by mail unless otherwise requested. Bonding companies must appear on Treasury Circular 570 and be authorized to transact business in the State of Oklahoma for an amount in excess of the bid.

A 100% PERFORMANCE BOND, 100% STATUTORY BOND AND 100% MAINTENANCE BOND in the amount of the CONTRACT PRICE, with a corporate surety approved by the COUNTY, will be required for the faithful performance of the contract. The Attorney-in-fact who signs the BID BONDS and PERFORMANCE, STATUTORY & MAINTENANCE BONDS must file with each BOND a certified and effective dated copy of their Power of Attorney.

Bidder will be responsible for overseeing the entire project.

The party to whom the contract is awarded will receive a NOTICE OF AWARD accompanied by the necessary AGREEMENT and BOND forms. The awarded bidder will be required to execute the Agreement and obtain the PERFORMANCE BOND, STATUTORY BOND, MAINTENANCE BOND and PUBLIC LIABILITY & WORKERS COMP INSURANCE within ten (10) calendar days from the date BID is awarded unless extended by mutual agreement between the COUNTY and the AWARDED BIDDER. In case of failure of the BIDDER to execute the AGREEMENT, the COUNTY may consider the BIDDER in default, in which case the BID BOND accompanying the proposal shall become the property of the COUNTY.

The NOTICE TO PROCEED shall be issued within seven (7) days of the execution of the AGREEMENT by the COUNTY. Should there be reasons why the NOTICE TO PROCEED cannot be issued within such period; the time may be extended by mutual agreement between the COUNTY and CONTRACTOR. If the NOTICE TO PROCEED has not been issued within the seven (7) day period or within the period mutually agreed upon, the CONTRACTOR may terminate the AGREEMENT without further liability on the part of either party.

The COUNTY may make such investigations as deemed necessary to determine the ability of the BIDDER to perform the WORK, and the BIDDER shall furnish to the COUNTY all such information, data and not limited to financial statements, for this purpose as the COUNTY may request. The COUNTY, reserves the right to REJECT any BID if the evidence submitted by, or investigation of, such BIDDER fails to satisfy the COUNTY that such BIDDER is properly qualified to carry out the obligations of the AGREEMENT and to complete the WORK contemplated therein.

All CONTRACTORS involved in the project shall have proper and current licensing in the State of Oklahoma and should be prepared to provide a copy of such if requested.

Bidder shall supply the names and addresses of major material suppliers & subcontractors with bid.

The Bidder must be able to financially carry on the work until project is completed.

Please NOTE this project is TAX EXEMPT as allowed by 68 O.S. § 1356. The successful bidder will be issued a copy of the Resolution designating them as an agent for the County for the purpose of purchasing materials and tangible personal property tax exempt for the construction (improvements, remodeling, renovation, repairing, etc.) of this project. If the tax exempt status is to be used, materials and tangible

personal property purchased by the Contractor and its subcontractors, to be used in this project, will be delivered to the jobsite and incorporated into the project. The title to such property is to pass from the vendor directly to the County. Bidder will be responsible for any tax not included in the exemption. If Sub-Contractors are to be included, their names must be provided to the Purchasing Agent prior to the time the Contract is entered into so that the Sub-Contractors can be listed on the Resolution. Such Resolution requires Board of County Commissioners approval at a regular scheduled meeting therefore your list of sub-contractors shall be submitted with your contract, insurance & bonds.

PAYMENT

Original Documents required:

- Invoice with breakdown of materials & labor.
- Application and Certificate of Payment with original signatures
- Certification from Commissioner Levi Krasser stating his Approval (document will be provided by District #3)
- One "Affidavit for Contracts & Payments" is required when total payments exceed \$25,000.00.

The Owner will make partial payments based upon work complete. Ten percent (10%) of all partial payments made shall be withheld as retainage. At any time the contractor has completed in excess of fifty percent (50%) of the total contract amount, the retainage shall be reduced to five percent (5%) of the amount earned to date if the Owner authorizes.

The Invoice, with attached items listed above, shall be submitted by the Contractor to the Tillman County Commissioners' Office, P.O. Box 992, 201 N. Main, Frederick, OK 73542. Before the Commissioner's Office submits the Invoice to the Purchasing Dept. to be paid, it shall contain certification by Commissioner Levi Krasser that states the work for which payment is claimed has been performed and that such work conforms to the specifications for the project. No such invoice shall be paid by the County without such certification. The Contractor must provide a signed Affidavit for Contracts & Payments which will be provided with the contract & bonds forms.

Upon completion of project, contractor shall furnish proof that all claims and obligations incurred by him in connection with this performance of said work have been fully paid and settled. Information shall be in the form of an affidavit provided by the Bonding Company, which shall bear the approval of the surety on the contract bonds for payment to the contractor. Lien Waivers from Subcontractors and Suppliers may also be required.

Liquidated damages shall be \$200.00 per day for each consecutive calendar day of delay until the work is completed or accepted excluding inclement weather days as mutually agreed upon by County and Contractor. Calendar days will start the date the Notice to Proceed is issued.

The jobsite shall be cleaned up on a daily basis. All trash and debris generated from the construction operation shall be delivered to the landfill at the Contractor's expense. Contractor is responsible for storage and security of all materials required for this contract.

Any spills of petroleum, oil & lubricant (POL) products, chemicals, or other hazardous materials must be reported immediately to Tillman County District #3 at 580-479-5236. The contractor shall then comply with the guidance of the Tillman County Emergency Management Director, (located at 1200 S. Main, Frederick, OK 73542; 580-335-7549 phone) in taking appropriate actions to rapidly control and/or contain any spills.

CONTRACTOR will be responsible for obtaining any permits required for the project. Contractor is responsible for safety of its personnel and all sub-contractors.

Contractor shall not hire persons not legally residing in the United States.

CHANGE ORDERS cannot exceed a 15% cumulative increase of the original contract amount. Change orders which exceed 15% shall require a re-advertising for bids on the incomplete portions of the contract.

Necessary changes shall be addressed to Commissioner Levi Krasser. **ALL** Change Orders shall be formally approved by the Board of Tillman County Commissioners and the reasons for approval recorded in the permanent records of the County. A Purchase Order will only be encumbered for the original contract amount. Therefore if a Change Order is necessary, a Purchase Order for the approved amount must be encumbered and it is the Contractors responsibility to communicate with the County to ensure a Purchase Order is in place for any Change Orders (overages).

DOCUMENTS REQUIRED FOR THIS BID

*Bid Form, includes an attached Letter of Authorization

*Business Relationship Affidavit

*Bid Security for 5% of the total bid.

*Affidavit for Filing with Competitive Bid

*IRS W9 Form

*see below

Bidder must submit the properly completed and executed documents listed on this page. All signatures must be original, not copied, faxed, computer generated or mechanical.

Bidder shall use the forms in this Bid Package or shall photocopy the forms and complete them. No alterations can be made to the forms except to add additional signature lines as required. Any other alteration or amendment of the forms may invalidate the Bid.

All correspondence will be in writing. In the event that it becomes necessary to revise any part of the Bid, addenda will be faxed, emailed or mailed to vendors on the Bid Holders List. Any oral interpretations or clarification of this Bid shall not be relied upon. All changes to this Bid must be in writing and available to all bidders.

******In addition to the Required Documents listed above, Bidder shall also provide all requested information in this bid packet. A written statement with this information may be provided with your bid if additional space is needed.

If a Bid Document listed above is not included in the Bid Packet, it is the Bidder's responsibility to obtain the Bid Document from the Tillman County Purchasing Dept. The Bidder shall also be responsible for contacting the Purchasing Agent prior to bid closing to ensure all addendums were received. A copy of each addendum must be present with the submitted bid package.

If you have questions regarding the bid specifications, contact Commissioner Levi Krasser at 580-479-5236 and if you have questions regarding the bid deadlines, etc., contact Cacy Caldwell at 580-335-3421 ext 3.

It is not intended for any of the specifications to be brand or company specific. If ever a brand is referenced, it is intended to be "similar or like item/company".

BID FORM

Proposal of _____
(hereinafter called "BIDDER"), organized and existing under the laws of the State of Oklahoma

doing business as _____
(Insert "a corporation", "a partnership" or "an individual" as applicable).

To the Board of Tillman County Commissioners _____ (hereinafter called "OWNER"):

The Bidder, in compliance with your Invitation to Bid for the

**GRANDFIELD PUBLIC SCHOOL PARKING LOTS PROJECT
IN DISTRICT #3, TILLMAN COUNTY, OKLAHOMA**

having examined the specifications with related documents and the site of the proposed work, and being familiar with all of the conditions surrounding the construction of the proposed project including the availability of materials and labor, hereby proposes to furnish all labor, materials, and the supplies, to construct the project in accordance with the Contract Documents, and at the bid price stated below.

Upon receipt of written notice of the acceptance of this bid, Bidder shall within ten **(10) calendar days**, execute the formal contract to be furnished by the Owner, deliver required bonds on the forms contained herein and provide proof of required insurance unless extended by mutual agreement between the County and the Awarded Bidder.

The Bidder hereby agrees to commence work under this Contract the week the Contract, Bonds & Insurance are approved, or as agreed upon with the owner, at which time a written Notice to Proceed will be given to the Bidder by the Owner and to fully complete the project within the number of calendar days thereafter stipulated in the Contract.

Calendar days will start the date the Notice to Proceed is issued. Bidder further agrees to pay as liquidated damages, the sum of \$200.00 for each consecutive calendar day thereafter excluding inclement weather days as mutually agreed upon by Owner and Bidder.

The Bidder acknowledges receipt of the following Addenda:

- 1) _____ Date _____
- 2) _____ Date _____
- 3) _____ Date _____

BASE PROPOSAL

(the Total Project Cost as shown on Exhibit "A")

I (We) agree to perform all of the work required by the bid documents, specifications and plans for the

**GRANDFIELD PUBLIC SCHOOL PARKING LOTS PROJECT
IN DISTRICT #3, TILLMAN COUNTY, OKLAHOMA**

for the sum of: \$ _____ dollars

(\$ _____) The amount shall be shown in both words and figures.
In case of discrepancy, the amount shown in words shall govern.

- Bidder proposes to complete project in _____ days.
- Bidder will be able to begin project _____ days after award date.
- Please list the estimated response time for requested service should problems arise: _____

The Bidder agrees that this bid shall be good and may not be withdrawn for a period of 60 calendar days after the actual opening thereof.

The bid security attached in the sum of _____ dollars (\$_____) is to become the property of the Owner in the event the contract, bonds and insurance are not executed within the time above set forth, as liquidated damages for the delay and additional expense to the Owner caused thereby.

Bidder understands, agrees and warrants:

The bidder has carefully read and fully understands the full scope of the Bid Documents and Contract Documents.

That bidder has the capability to successfully undertake and complete the responsibilities and obligations in said Bid Documents and Contract Documents. The Tillman County Board of Commissioners is in no way permitted to provide payments prior to goods received and services performed.

The Tillman County Board of Commissioners reserves the right to award or reject any or all bids and waive any informality. The Board also reserves the right to accept all or part of any bid offered and to accept that bid or part of that bid which will, in the County's opinion, best serve the public interest.

BIDDER: _____
Name of Corporation or Firm

By: _____
Signature of Bidder or Bidder's Authorized Agent, see "Letter of Authorization" attached

_____ Print Bidders Name Above

TITLE: _____ DATE: _____
Please provide documentation stating officers for the company

MAILING ADDRESS CITY STATE ZIP

PHONE FAX EMAIL

***SUB-CONTRACTORS:**

NAME

ADDRESS

***PROJECT SCHEDULE/TIMELINE**

COMMENTS:

EXHIBIT "A"
GRANDFIELD PUBLIC SCHOOLS
PARKING LOTS PROJECT
IN DISTRICT #3, TILLMAN COUNTY, OKLAHOMA

PAY QUANTITIES
(shown on Sheet 2 of Plans)

ITEM	DESCRIPTION	UNIT	QTY	UNIT PRICE	ITEM TOTAL
202(A) 2210	UNCLASSIFIED EXCAVATION (1)	CY	85.00		
303(A) 1200	AGGREGATE BASE TYPE A (2)	CY	36.00		
402(A) 2200	TRAFFIC BOUND SURFACE COURSE TYPE E (R-20)	TON	1052.00		
407(B) 7300	TACK COAT (3)	GAL	1648.00		
408 8100	PRIME COAT (R-23)	GAL	191.00		
411(C) 1430	SUPERPAVE, TYPE S4 (PG -64-22 OK) (R-26)(4)	TON	2266.00		
411(I) 2000	SUPERPAVE, TYPE S4 (PATCH) (PG -64-22 OK) (R26)(5)	TON	100.00		
412 3100	COLD MILLING PAVEMENT (6)	SY	373.00		
509(D) 0500	CLASS C CONCRETE (7)	CY	41.00		
805(D) 3528	(PL) REMOVE AND RESET EXISTING SIGNS	EA	8.00		
854(A) 6201	(SP) TRAFFIC STRIPE (PAINT)(4" WIDE)	LF	12915.00		
854(B) 6301	(SP) TRAFFIC STRIPE (PAINT)(ARROW)	EA	2.00		
854(B) 6321	(SP) TRAFFIC STRIPE (PAINT)(SYMBOLS) (9)	EA	6.00		
855(A) 7217	(SP) TRAFFIC STRIPE (PLASTIC)(24" WIDE) (10)	LF	536.00		
880(J) 7110	CONSTRUCTION TRAFFIC CONTROL (11)	LSUM	1.00		
	(PL) PARKING BUMPERS (12)	EA	6.00		
TOTAL PROJECT COST					

THE COMANCHE NATION
DIVISION OF TRANSPORTATION
IN COOPERATION WITH
TILLMAN COUNTY DISTRICT #3

PLAN OF PROPOSED
GRANDFIELD PUBLIC SCHOOL
PARKING LOTS
TILLMAN COUNTY, OKLAHOMA

BIA PROJECT NO. _____

SHEET NO.	DESCRIPTION
1.	TITLE SHEET
2.	TYPICAL SECTION, DETAILS, QUANTITIES AND NOTES
3.	SIGNING AND STRIPING DETAILS
4-10.	PLAN VIEW

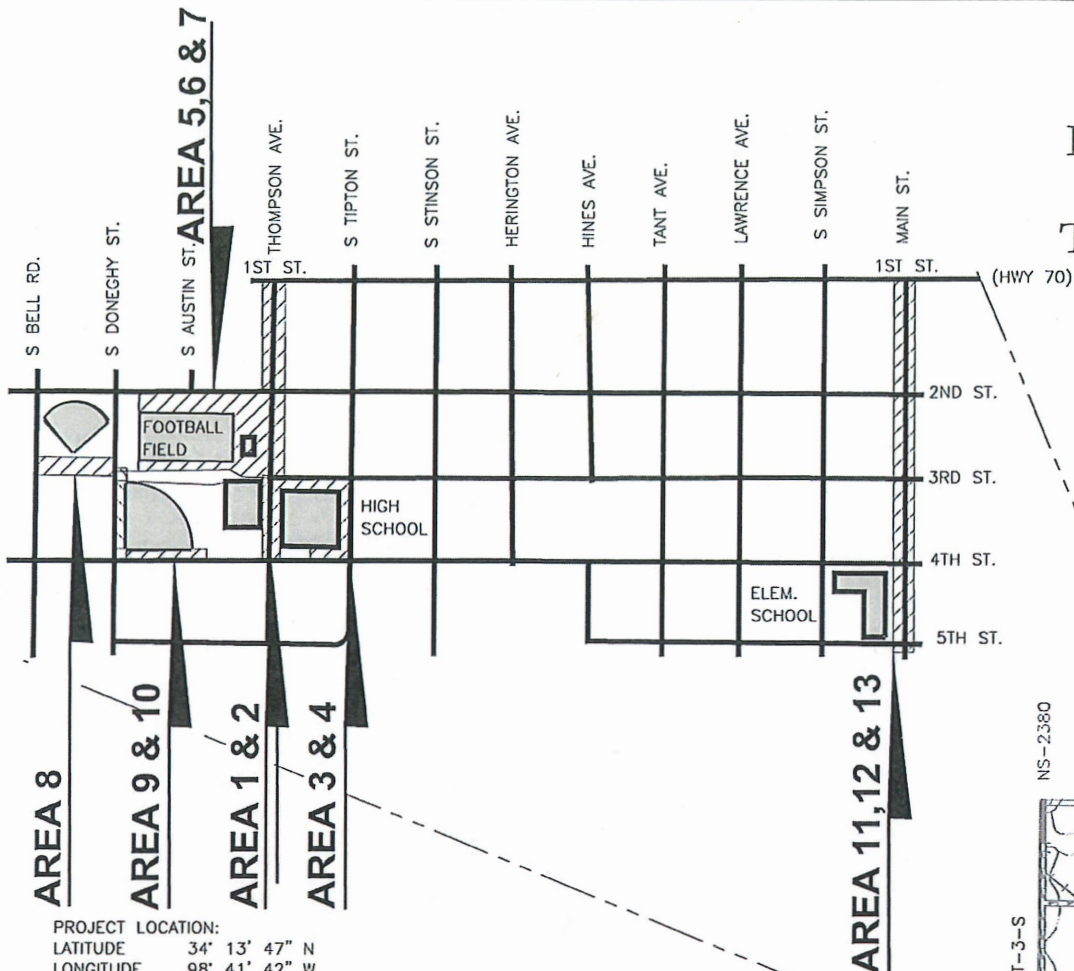

PROJECT LOCATION:
LATITUDE 34° 13' 47" N
LONGITUDE 98° 41' 42" W

NO SURVEY DATA WAS COLLECTED FROM THE SITE FOR THIS PROJECT.

SCALES

PLAN 1"=50'
PROFILE HOR. N/A
VER. N/A
LOCATION MAP 1"=10,560'

CONVENTIONAL SIGNS

- PROPOSED ROADS
- SECTION LINES
- QUARTER SECTION LINES
- x-x FENCES
- EXISTING GRADE
- EXISTING ROADS
- BASE LINE
- PROPOSED GRADE
- TUG-TUG- COMMUNICATION LINES (EXISTING)
- AA- POWER LINES (EXISTING)
- G-G- GAS LINE (EXISTING)
- SS-SS- SANITARY SEWER LINES (EXISTING)
- W-W- WATER LINES (EXISTING)
- COMMUNICATION LINES (PROPOSED)
- POWER LINES (PROPOSED)
- G-G- GAS LINE (PROPOSED)
- SS-SS- SANITARY SEWER LINES (PROPOSED)
- W-W- WATER LINES (PROPOSED)
- BUILDINGS
- DRAINAGE STRUCTURES (EXISTING)
- DRAINAGE STRUCTURES (PROPOSED)
- RIGHT-OF-WAY LINES (EXISTING)
- RIGHT-OF-WAY LINES (PROPOSED)
- RIGHT-OF-WAY FENCE
- FLOWLINE (EXISTING)
- FLOWLINE (PROPOSED)
- TOE OF SLOPE (EXISTING)
- TOE OF SLOPE (PROPOSED)
- CITY LIMITS
- LANDSCAPE

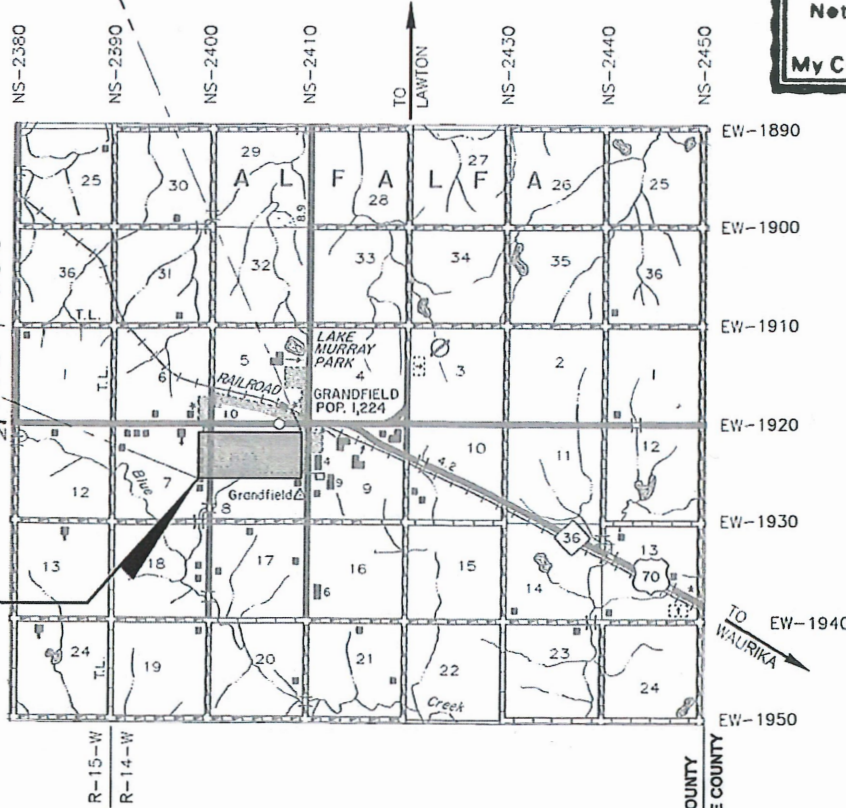

PROJECT LOCATION

PROJECT AREAS BASED ON GOOGLE EARTH AERIAL IMAGE

PROJECT AREA: 26,447 SQ. YD. 5.464 ACRES
EXCEPTIONS:NONE
EQUATIONS:NONE

SARAH BETH HARRISON
Notary Public, State of Oklahoma
Commission # 24015095
My Commission Expires 12/13/28

APPROVED
GRANDFIELD SCHOOL DISTRICT
David [Signature]
SUPERINTENDENT: _____
DATE: 7-23-25

ATTEST
Sarah Beth Harrison
DATE: 7-23-25

APPROVED
TILLMAN COUNTY BOARD OF COMMISSIONERS
[Signature]
DISTRICT NO. 1 _____
DATE: 7/7/2025

DISTRICT NO. 2 _____
DATE: 7/7/2025

DISTRICT NO. 3 _____
DATE: 7/7/2025

ATTEST
Cace Caldwell
COUNTY CLERK
DATE: July 7 2025



PREPARED BY:
CEC CORPORATION
CA32 6/30/26
OKLAHOMA CITY, OKLAHOMA

Lauren Romano
LAUREN ROMANO
OKLA. REG. NO. 30415

6/24/25
DATE

U.S. DEPARTMENT OF THE INTERIOR
BUREAU OF INDIAN AFFAIRS

IN COOPERATION WITH THE
COMANCHE NATION OF OKLAHOMA

DATE APPROVED: 8/4/2025
BY: *[Signature]*
REGIONAL ROAD ENGINEER (ACTING)

Adrian Shaw
DATE: _____
SHEET NO. 1

SPECIFICATIONS: 2019 OKLAHOMA STANDARD SPECIFICATIONS FOR HIGHWAY CONSTRUCTION, AS APPROVED BY THE U.S. DEPARTMENT OF TRANSPORTATION, FEDERAL HIGHWAY ADMINISTRATION, DECEMBER 18, 2019, EXCEPT AS MODIFIED BY THE PLANS AND SPECIAL PROVISIONS.

PAY QUANTITIES				
ITEM		DESCRIPTION	UNITS	QUANTITY
202(A)	2210	UNCLASSIFIED EXCAVATION (1)	CY	85.00
303(A)	1200	AGGREGATE BASE TYPE A (2)	CY	36.00
402(A)	2200	TRAFFIC BOUND SURFACE COURSE TYPE E (R-20)	GAL	1,052.00
407(B)	7300	TACK COAT (3)	GAL	1,648.00
408	8100	PRIME COAT (R-23)	GAL	191.00
411(C)	1430	SUPERPAVE, TYPE S4(PG 64-22 OK) (R-26)(4)	TON	2,266.00
411(I)	2000	SUPERPAVE, TYPE S4(PATCH)(PG 64-22 OK) (R-26)(5)	TON	100.00
412	3100	COLD MILLING PAVEMENT (6)	SY	373.00
509(D)	0500	CLASS C CONCRETE (7)	CY	41.00
805(D)	3528	(PL) REMOVE AND RESET EXISTING SIGNS (8)	EA	8.00
854(A)	6201	(SP) TRAFFIC STRIPE(PAINT)(4" WIDE)	LF	12,915.00
854(B)	6301	(SP) TRAFFIC STRIPE(PAINT)(ARROW)	EA	2.00
854(B)	6321	(SP) TRAFFIC STRIPE(PAINT)(SYMBOLS) (9)	EA	6.00
855(A)	7217	(SP) TRAFFIC STRIPE(PLASTIC)(24" WIDE) (10)	LF	536.00
880(J)	7110	CONSTRUCTION TRAFFIC CONTROL (11)	LSUM	1.00
		(PL) PARKING BUMPERS (12)	EA	6.00

PAY QUANTITY NOTES

- (R-20) ESTIMATED AT 140 LBS. PER CU. FT.
- (R-23) PRIME COAT SHOULD BE APPLIED AT AN ESTIMATED RATE OF 0.35 GAL. PER SQ. YARD WHEN APPLIED TO SUBGRADE, AND 0.25 GAL. PER SQ. YARD WHEN APPLIED TO AGGREGATE BASE. THE ACTUAL CUTBACK PRIME COAT REQUIRED FOR PLACEMENT OPERATIONS WILL BE DETERMINED BY THE CONTRACTOR, AND SHALL CONSIDER THE RESIDUE FROM DISTILLATION PERCENTAGE SHOWN IN SECTION 708.03 OF THE STANDARD SPECIFICATION.
- (R-26) ESTIMATED AT 112 LBS. PER SQ. YD. PER 1" THICK.
 - (1) PAY ITEM INCLUDES REMOVAL OF 7" FROM EXISTING SURFACE. PAY ITEM SHALL INCLUDE INCIDENTAL SHAPING AS INDICATED ON THE PLANS AND DIRECTED BY THE INSPECTOR. MATERIAL TO BE DISPOSED OF BY THE CONTRACTOR.
 - (2) CONTRACTOR SHALL PROVIDE PROCTOR AND DENSITY TEST ON THE SUBGRADE AND/OR TYPICAL SECTION AT UP TO 3 LOCATIONS WITHIN THE PROJECT LIMITS AS DIRECTED BY THE INSPECTOR. FINAL TYPICAL SECTION MAY VARY IF EXISTING SURFACE IS FOUND TO BE AN ACCEPTABLE SUBSTITUTE FOR SUBGRADE AND/OR AGGREGATE BASE, AS DETERMINED BY THE INSPECTOR. FIELD ADJUSTMENTS BASED ON INSPECTION RESULTS WILL BE AT THE COMANCHE NATION'S DISCRETION. CORE SAMPLE LOCATIONS ARE TO BE BACKFILLED BY THE CONTRACTOR ACCORDING TO INDUSTRY STANDARDS.
 - (3) ESTIMATED AT 0.085 GALLONS PER SQUIRE YARD OF ORIGINAL EMULSION OF TACK COAT (BEFORE DILUTION FOR APPLICATION) WHEN APPLIED OVER OLD ASPHALT AND 0.060 GALLONS PER SQUARE YARD OF ORIGINAL EMULSION OF TACK COAT (BEFORE DILUTION FOR APPLICATION) WHEN APPLIED UNDER FIRST LAYER OF S4 SUPERPAVE IN ACCORDANCE WITH SECTION 407.04C OF THE STANDARD SPECIFICATIONS. SEE TABLE 407:1 FOR THE APPLICATION RATES.
 - (4) INCLUDES AN ALLOWANCE OF 40 TONS FOR EDGE OF PAVEMENT TRANSITIONS (SEE DETAIL THIS SHEET).
 - (5) ITEM INCLUDES AN ALLOWANCE OF 100 TONS TO BE DELIVERED ON SITE AND USED FOR BLADE/HAND PATCHING IN ADVANCE OF ROADWAY OVERLAY. THE COUNTY AND CONTRACTOR SHALL COORDINATE WITH EACH OTHER TO COMPLETE THIS WORK.
 - (6) COLD MILLING SHALL CONSIST OF COLD MILLING EXISTING PAVEMENT IN A MANNER APPROVED BY THE INSPECTOR AND IN ACCORDANCE WITH SECTION 412 OF THE 2019 OKLAHOMA STANDARD SPECIFICATIONS FOR HIGHWAY CONSTRUCTION. ALL MILLINGS SHALL BECOME THE PROPERTY OF THE SCHOOL AND BE STOCKPILED IN ONE LOCATION AT A SITE DETERMINED BY THE SCHOOL WITHIN 1 MILE OF THE PROJECT OR IN A MANNER APPROVED BY THE INSPECTOR. MILLING LOCATIONS INCIDENTAL TO THE PROJECT AROUND PAVEMENT TRANSITION AREAS TO CONCRETE, SURFACE OBSTRUCTIONS SUCH AS DRAINAGE STRUCTURES, FLUSH MOUNT WATER VALVE BOXES OR MAN HOLES SHALL BE INCLUDED IN THIS ITEM AT NO EXTRA COST. COLD MILLING PAVEMENT SHALL INCLUDE COST OF SAW-CUTTING AT PAVEMENT TRANSITIONS.
 - (7) PAY ITEM INCLUDES ALL MATERIALS AND LABOR TO CONSTRUCT A: 14'X20' AND 34'X20' CONCRETE PAD 8" THICK WITH A SINGLE MAT OF #4 REBAR SPACED AT 12" C/C LONGITUDINALLY AND TRANSVERSELY. THE CONTRACTOR SHALL BROOM FINISH THE SURFACE.
 - (8) PAY ITEM INCLUDES REMOVAL AND RESETTING OF ALL SIGNS, HANDRAILS, AND INCIDENTAL ITEMS IN CONFLICT WITH CONSTRUCTION, AS DIRECTED BY THE INSPECTOR. INCLUDES ALL NECESSARY MATERIALS AND HARDWARE AS DETAILED IN THE PLANS FOR INSTALLATION OF NEW ADA PARKING SIGNS.
 - (9) QUANTITY INCLUDES ALL MATERIAL AND LABOR FOR 10 ADA PARKING SYMBOLS AND PAINTING PARKING BUMPERS BLUE.
 - (10) ESTIMATE INCLUDES QUANTITY FOR 24" WIDE STOP BARS AND PEDESTRIAN CROSSINGS.
 - (11) CONSTRUCTION TRAFFIC CONTROL SHALL INCLUDE ALL BARRICADES AND SIGNS REQUIRED ON EACH END OF THE CONSTRUCTION AREA AND OTHER AREAS DESIGNATED BY THE ENGINEER. THE CONTRACTOR SHALL BE RESPONSIBLE FOR ALL CONSTRUCTION SIGNS, BARRICADES, LIGHTS, ETC. AS REQUIRED, ACCORDING TO THE STANDARDS SET FORTH IN THE MANUAL ON UNIFORM TRAFFIC CONTROL DEVICES, CURRENT EDITION, AND AS SHOWN ON THE STANDARD DRAWINGS. COST OF ALL NECESSARY CONSTRUCTION SIGNING WILL BE INCLUDED IN THE LUMP SUM PRICE BID FOR "CONSTRUCTION TRAFFIC CONTROL."
 - (12) PARKING BUMPERS, HARDWARE, AND INSTALLATION SHALL BE INCLUDED IN THIS ITEM. ESTIMATE INCLUDES 6 PARKING BUMPERS. PAY ITEM SHALL INCLUDE INSPECTION, REMOVAL, AND RESETTING OF ANY EXISTING PARKING BUMPERS ON SITE PRIOR TO PURCHASING NEW PARKING BUMPERS, AS APPROVED BY THE INSPECTOR.

GENERAL NOTES

SPECIFICATIONS: 2019 OKLAHOMA STANDARD SPECIFICATIONS FOR HIGHWAY CONSTRUCTION, AS APPROVED BY THE U.S. DEPARTMENT OF TRANSPORTATION, FEDERAL HIGHWAY ADMINISTRATION, DECEMBER 18, 2019, EXCEPT AS MODIFIED BY THE PLANS AND SPECIAL PROVISIONS.

THE CONTRACTOR SHALL CONSTRUCT ONE PARKING AREA AT A TIME UNLESS MUTUAL APPROVAL IS SECURED FROM THE COMANCHE NATION AND GRANDFIELD SCHOOLS.

FINAL TYPICAL SECTION MAY VARY IF EXISTING SURFACE IS FOUND TO BE AN ACCEPTABLE SUBSTITUTE FOR SUBGRADE AND/OR AGGREGATE BASE, AS DETERMINED BY THE INSPECTOR. FIELD ADJUSTMENTS BASED ON INSPECTION RESULTS WILL BE AT THE COMANCHE NATION'S DISCRETION. CORE SAMPLE LOCATIONS ARE TO BE BACKFIELD BY THE CONTRACTOR ACCORDING TO INDUSTRY STANDARDS.

PRIME COAT SHALL BE APPLIED TO THE AGGREGATE BASE IMMEDIATELY AFTER FINAL COMPACTION AND SHAPING.

IN ACCORDANCE WITH THE OKLAHOMA UNDERGROUND FACILITIES DAMAGE PREVENTION ACT THE CONTRACTOR SHALL NOTIFY THE OKLAHOMA ONE-CALL SYSTEM, INC. "CALL OKIE" 1-800-522-6543 48 HOURS PRIOR TO BEGINNING EXCAVATION. THE CONTRACTOR SHALL VERIFY ALL UTILITY LOCATIONS AND ELEVATIONS PRIOR TO CONSTRUCTION.

THE CONTRACTOR SHALL NOTIFY THE COMANCHE NATION, GRANDFIELD PUBLIC SCHOOLS, TILLMAN COUNTY DISTRICT 3 COMMISSIONER AND THE TOWN OF GRANDFIELD.

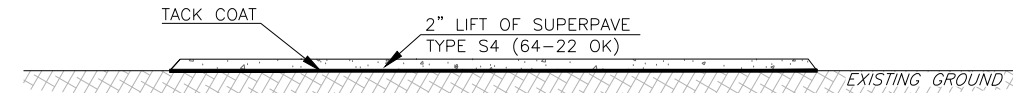

*** TYPICAL OVERLAY SECTION FOR AREAS 1,2,3,4,5,12 AND 13**

NOT TO SCALE

* TYPICAL SECTION SUBJECT TO CHANGE UPON RESULT OF EXISTING SURFACE DENSITY TESTING.

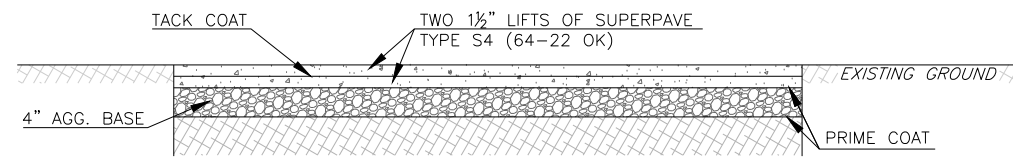

*** TYPICAL FULL DEPTH SECTION FOR AREA 11**

NOT TO SCALE

* TYPICAL SECTION SUBJECT TO CHANGE UPON RESULT OF EXISTING SURFACE DENSITY TESTING.

** TO BE COMPACTED TO AT LEAST 95% OF MAXIMUM DENSITY AND WITHIN 2% OF OPTIMUM MOISTURE CONTENT PER SECTION 204.04.A(5)(b)2. MOISTURE CONTENT SHALL BE VERIFIED IMMEDIATELY PRIOR TO THE PLACEMENT OF THE PAVEMENT SECTION. COST TO BE INCLUDED IN OTHER ITEMS OF WORK.



TYPICAL TBSC OVERLAY SECTION FOR AREAS 6,7,8,9 AND 10

NOT TO SCALE

TBSC SHALL BE COMPACTED TO 95% DENSITY OR AS DIRECTED BY THE INSPECTOR.

** TO BE COMPACTED TO AT LEAST 95% OF MAXIMUM DENSITY AND WITHIN 2% OF OPTIMUM MOISTURE CONTENT PER SECTION 204.04.A(5)(b)2. MOISTURE CONTENT SHALL BE VERIFIED IMMEDIATELY PRIOR TO THE PLACEMENT OF THE PAVEMENT SECTION. COST TO BE INCLUDED IN OTHER ITEMS OF WORK.

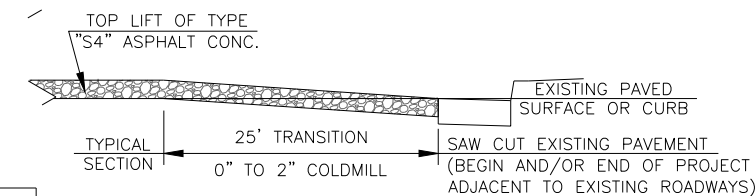

TYPICAL ROADWAY PAVEMENT TRANSITION

NOT TO SCALE

ADDITIONALLY, THE CONTRACTOR SHALL CONSTRUCT 5' COLDMILL TRANSITIONS IN THE EXISTING PAVEMENT NEAR, CONCRETE PAVEMENT TRANSITIONS, STORM DRAINS, MAN HOLES, WATER VALVES AND ANY OTHER FACILITY OBSTRUCTIONS ENCOUNTERED. CONTRACTOR TO VERIFY LOCATIONS IN THE FIELD. ALL COST TO BE INCLUDED IN PAY ITEM "COLD MILLING PAVEMENT". ALL DRIVEWAY ASPHALT TRANSITIONS SHALL TAPER FROM 2" TO 0" WITHIN 2' OF THE EDGE OF OVERLAY PAVEMENT. CONCRETE ALONG MAIN STREET SHALL NOT RECEIVE MILLING TRANSITIONS. THE CONTRACTOR SHALL CONTACT THE CITY A MINIMUM OF 2 WEEKS IN ADVANCE TO ALLOW COORDINATION TIME, SHOULD THE CITY CHOOSE TO REMOVE AND RESET ANY MANHOLE TOP RINGS OR WATER VALVES DURING OPERATIONS. A 2' WIDE TRANSITION FROM 2" TO 0" SHALL BE CONSTRUCTED THROUGH ALL INTERSECTIONS (AND SURFACE OBSTRUCTIONS SHOULD THE CITY CHOOSE TO NOT RESET TOP RINGS).

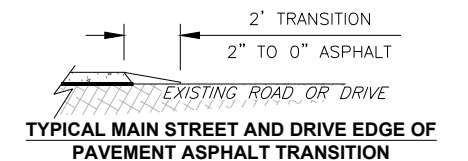

TYPICAL MAIN STREET AND DRIVE EDGE OF PAVEMENT ASPHALT TRANSITION

SUMMARY OF ESTIMATED QUANTITIES														
LOCATION	ESTIMATED AREA (SF)	TRAFFIC STRIPE (PAINT)(WHITE) (4" WIDE) (LF)	TRAFFIC STRIPE (PAINT)(WHITE) (24" WIDE) (LF)	T.B.S.C. TYPE E (TON)	ASPHALT SUPERPAVE, TYPE S4 (PG 64-22 OK) (TON)	COLD MILLING (SY)	AGGREGATE BASE (CY)	COMPACTED SUBGRADE (SY)	UNCLASSIFIED EXCAVATION (CY)	PRIME COAT (GAL)	TACK COAT (GAL)	SYMBOLS (EA)	PARKING BUMPERS (EA)	ARROWS (EA)
AREA 1	30,584	2,044	148		381 2" ASPHALT	159					289			
AREA 2	47,492	3,668			592 2" ASPHALT				6		449	3	6	
AREA 3	18,637	1,426	62		232 2" ASPHALT	104					177			
AREA 4	23,742	1,805			296 2" ASPHALT						225	3		
AREA 5	4,498	666			84 3" ASPHALT				17		45			
AREA 6	16,579			291										
AREA 7	17,520			307										
AREA 8	15,569			273										
AREA 9	5,932			104										
AREA 10	4,348			77										
AREA 11	2,864	500			54 2" ASPHALT		36	319	62	191	20			
AREA 12	9,734	482			122 2" ASPHALT						92	4		2
AREA 13	37,326	2,370	316		465 2" ASPHALT	110					353			
TOTALS	234,825	12,961	526	1,052	2,226	373	36	319	85	191	1,650	10	6	2

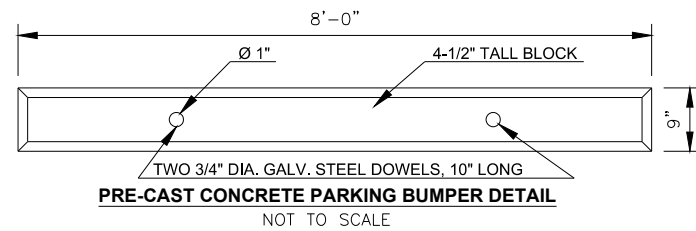
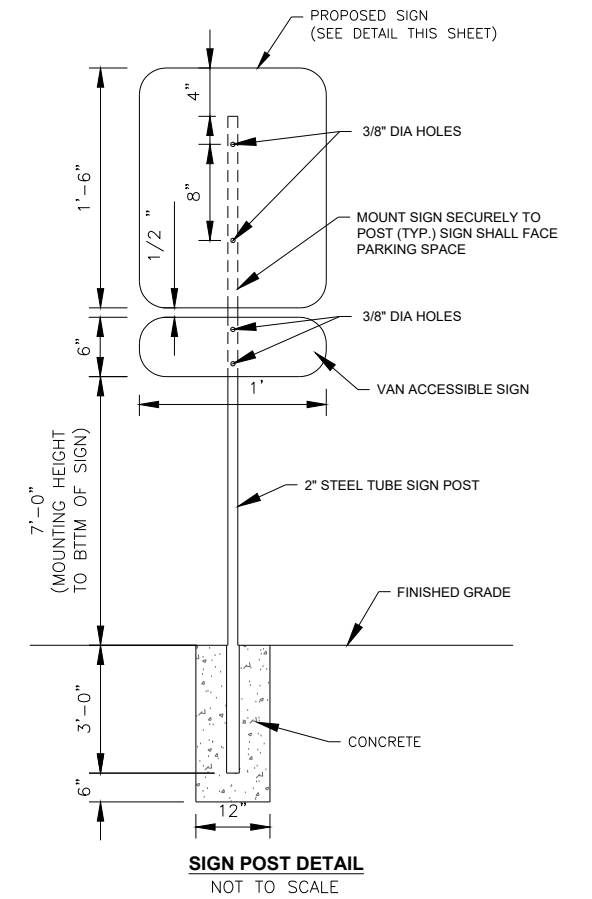
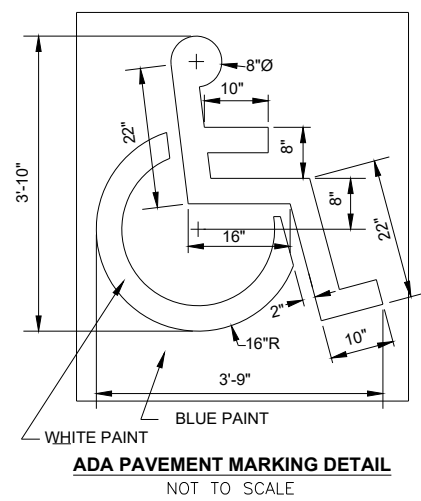
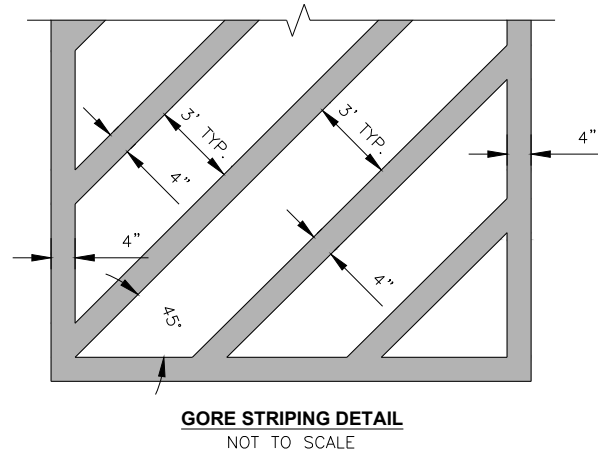



CONSTRUCTION NOTES:

1. ALL WORK PERFORMED AND MATERIALS SUPPLIED SHALL CONFORM TO ODOT STANDARDS AND SPECIFICATIONS AND THE COMANCHE NATION.
2. THE CONTRACTOR SHALL OBSERVE THE EXISTING FLOW OF WATER AND PRESERVE THE NATURAL PATHS THROUGH THE PARKING LOT AREA. THE CONTRACTOR SHALL REMOVE EXCESS EARTH AND SMOOTH ELEVATION CHANGES IN AREAS THAT DO NOT HAVE AN EXISTING PAVED SURFACE, AS APPROVED BY THE INSPECTOR.
3. THE CONTRACTOR SHALL BE RESPONSIBLE FOR NOTIFYING ALL UTILITY COMPANIES AND GOVERNMENTAL AGENCIES WHO MIGHT HAVE UTILITY LINES ON OR ABOUT THE PREMISES, OR WHO MIGHT BE AFFECTED BY THE CONSTRUCTION. THE CONTRACTOR SHALL ALSO COORDINATE HIS ACTIVITIES WITH THE UTILITY COMPANIES TO ENSURE COMPLIANCE WITH THE PROJECT SCHEDULE. THE CONTRACTOR SHALL MAKE EVERY EFFORT TO LOCATE AND PROTECT EXISTING UTILITY LINES, AND SHALL REPAIR ANY DAMAGES.
4. THE CONTRACTOR SHALL BE RESPONSIBLE FOR HIS OWN CONSTRUCTION STAKING AND ELEVATION GRID SURVEY IF REQUIRED TO DRAIN THE PROJECT. COST OF CONSTRUCTION STAKING TO BE INCLUDED IN OTHER ITEMS.
5. IF FULL DEPTH RECONSTRUCTION IS TO BE PERFORMED AT AREA 5 AFTER ALL REQUESTED PROCTOR AND DENSITY TESTS ARE COMPLETE, THE GROUND SHALL BE STRIPPED SEVEN INCHES (7") OF EXISTING GRAVEL OR TOPSOIL. SUBGRADE SHALL BE COMPACTED TO AT LEAST 95% MAXIMUM DENSITY BEFORE PLACING FOUR INCHES(4") OF AGGREGATE BASE ATOP THE SUBGRADE AND COMPACTING TO 98% OF MAXIMUM DENSITY.
6. ALL SIGNS, PAVEMENT MARKINGS, AND OTHER TRAFFIC CONTROL DEVICES SHALL CONFORM TO THE MANUAL ON UNIFORM TRAFFIC CONTROL DEVICES, LATEST EDITION.
7. ALL PAVEMENT PAINT STRIPING SHALL BE APPLIED IN ONE COAT, FOUR (4) INCHES WIDE, WHITE, UNLESS SHOWN OTHERWISE ON THE PLANS.
8. THE CONTRACTOR SHALL SWEEP CLEAN ALL SOLID SURFACES PRIOR TO PLACING ASPHALT OVERLAY.
9. ALL PARKING BUMPERS WITHIN ADA SPACES SHALL BE PAINTED BLUE.
10. THE CONTRACTOR SHALL COORDINATE WITH TILLMAN COUNTY DISTRICT 2 COMMISSIONER LEVI KRASSER AT 580-512-6834 WHO WILL COMPLETE ANY NECESSARY BLADE PATCHING AND POTHOLE PATCHING OPERATIONS.
11. TWO CONCRETE PADS FOR TRASH DUMPSTERS SHALL BE CONSTRUCTED 8" THICK (14'X20' AND 34'X20') WITH #4 REBAR SPACED AT 12" C/C. ALL MATERIALS REQUIRED ARE TO BE INCLUDED IN PAY ITEM CLASS C CONCRETE.
12. ALL ADA PARKING AND ADJACENT ACCESS AISLES SHALL HAVE A MAXIMUM SLOPE OF 2% IN ANY DIRECTION.

PARKING SUMMARY

PROPOSED STANDARD PARKING PROVIDED: 86
 PROPOSED ADA PARKING PROVIDED: 6

LEGEND

	PROPOSED GORE AREA		PROPOSED ADA SIGN
	PROPOSED 2" ASPHALT OVERLAY		PROPOSED STOP BAR
	PROPOSED COLDMILL TRANSITION		DIRECTIONAL ARROW
	PROPOSED CONCRETE PAD		PROPOSED ADA PARKING
			PROPOSED PARKING BUMPER
			PROPOSED CROSS WALK

GRANDFIELD PUBLIC SCHOOL COMANCHE NATION

**PLAN VIEW
SHEET 1 OF 7**

SHEET NO. 4

MATCH LINE "B"

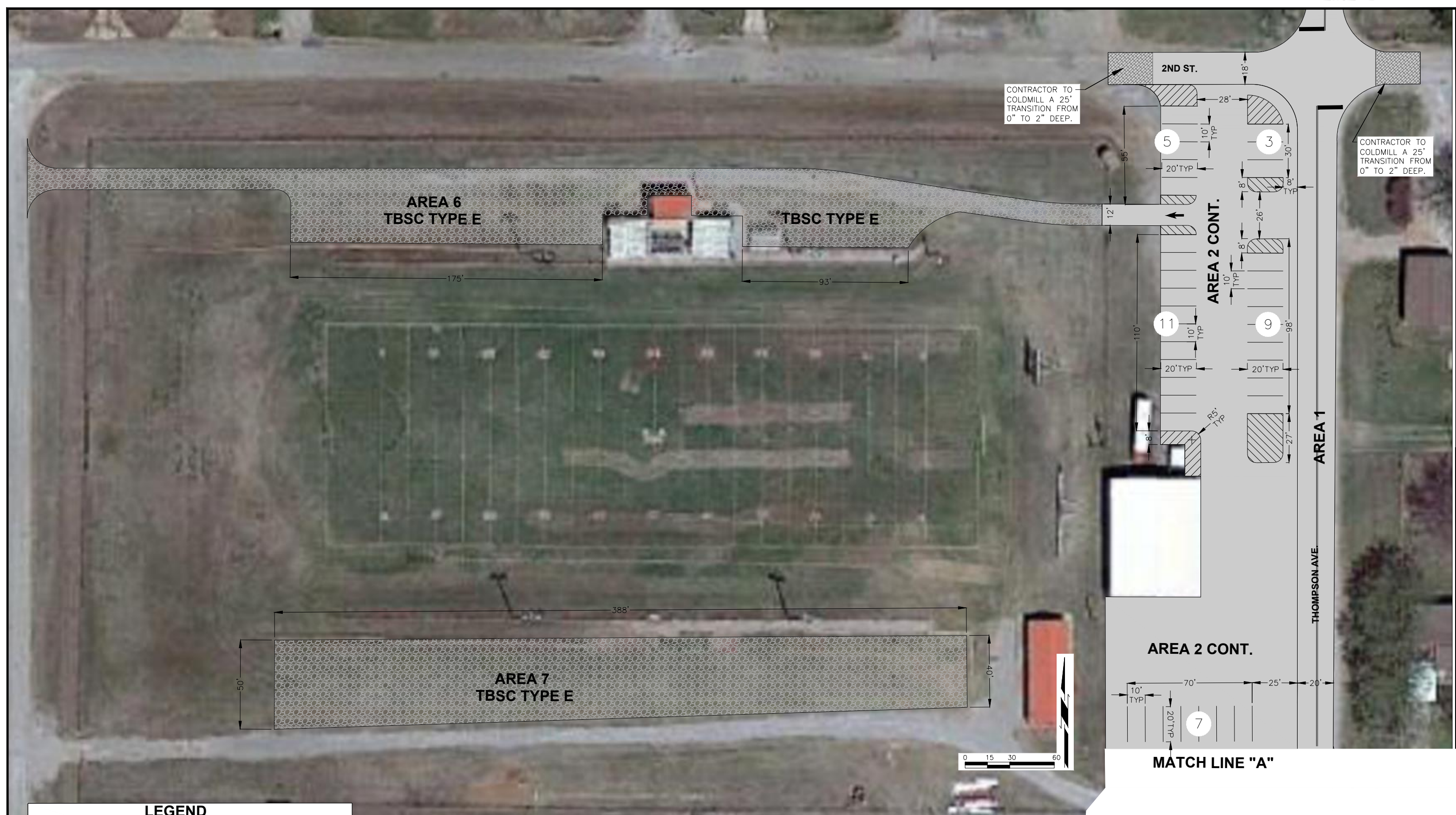

CONTRACTOR TO COLDMILL A 25' TRANSITION FROM 0" TO 2" DEEP.

CONTRACTOR TO COLDMILL A 25' TRANSITION FROM 0" TO 2" DEEP.

LEGEND

	PROPOSED GORE AREA		PROPOSED ADA SIGN
	PROPOSED 2" ASPHALT OVERLAY		DIRECTIONAL ARROW
	PROPOSED COLDMILL TRANSITION		PROPOSED ADA PARKING
			PROPOSED 3" TBSC

PARKING SUMMARY

PROPOSED STANDARD PARKING PROVIDED: 35

GRANDFIELD PUBLIC SCHOOL COMANCHE NATION

PLAN VIEW SHEET 2 OF 7





MATCH LINE "B"

CONSTRUCTION NOTES:

1. ALL WORK PERFORMED AND MATERIALS SUPPLIED SHALL CONFORM TO ODOT STANDARDS AND SPECIFICATIONS AND THE COMANCHE NATION.
2. THE CONTRACTOR SHALL OBSERVE THE EXISTING FLOW OF WATER AND PRESERVE THE NATURAL PATHS THROUGH THE PARKING LOT AREA. THE CONTRACTOR SHALL REMOVE EXCESS EARTH AND SMOOTH ELEVATION CHANGES IN AREAS THAT DO NOT HAVE AN EXISTING PAVED SURFACE, AS APPROVED BY THE INSPECTOR.
3. THE CONTRACTOR SHALL BE RESPONSIBLE FOR NOTIFYING ALL UTILITY COMPANIES AND GOVERNMENTAL AGENCIES WHO MIGHT HAVE UTILITY LINES ON OR ABOUT THE PREMISES, OR WHO MIGHT BE AFFECTED BY THE CONSTRUCTION. THE CONTRACTOR SHALL ALSO COORDINATE HIS ACTIVITIES WITH THE UTILITY COMPANIES TO ENSURE COMPLIANCE WITH THE PROJECT SCHEDULE. THE CONTRACTOR SHALL MAKE EVERY EFFORT TO LOCATE AND PROTECT EXISTING UTILITY LINES, AND SHALL REPAIR ANY DAMAGES.
4. THE CONTRACTOR SHALL BE RESPONSIBLE FOR HIS OWN CONSTRUCTION STAKING AND ELEVATION GRID SURVEY IF REQUIRED TO DRAIN THE PROJECT. COST OF CONSTRUCTION STAKING TO BE INCLUDED IN OTHER ITEMS.
5. IF FULL DEPTH RECONSTRUCTION IS TO BE PERFORMED AT AREA 5 AFTER ALL REQUESTED PROCTOR AND DENSITY TESTS ARE COMPLETE, THE GROUND SHALL BE STRIPPED SEVEN INCHES (7") OF EXISTING GRAVEL OR TOPSOIL. SUBGRADE SHALL BE COMPACTED TO AT LEAST 95% MAXIMUM DENSITY BEFORE PLACING FOUR INCHES(4") OF AGGREGATE BASE ATOP THE SUBGRADE AND COMPACTING TO 98% OF MAXIMUM DENSITY.
6. ALL SIGNS, PAVEMENT MARKINGS, AND OTHER TRAFFIC CONTROL DEVICES SHALL CONFORM TO THE MANUAL ON UNIFORM TRAFFIC CONTROL DEVICES, LATEST EDITION.
7. ALL PAVEMENT PAINT STRIPING SHALL BE APPLIED IN ONE COAT, FOUR (4) INCHES WIDE, WHITE, UNLESS SHOWN OTHERWISE ON THE PLANS.
8. THE CONTRACTOR SHALL SWEEP CLEAN ALL SOLID SURFACES PRIOR TO PLACING ASPHALT OVERLAY.
9. ALL PARKING BUMPERS WITHIN ADA SPACES SHALL BE PAINTED BLUE.
10. THE CONTRACTOR SHALL COORDINATE WITH TILLMAN COUNTY DISTRICT 2 COMMISSIONER LEVI KRASSER AT 580-512-6834 WHO WILL COMPLETE ANY NECESSARY BLADE PATCHING AND POTHOLE PATCHING OPERATIONS.
11. TWO CONCRETE PADS FOR TRASH DUMPSTERS SHALL BE CONSTRUCTED 8" THICK (14'X20' AND 34'X20') WITH #4 REBAR SPACED AT 12" C/C. ALL MATERIALS REQUIRED ARE TO BE INCLUDED IN PAY ITEM CLASS C CONCRETE.
12. ALL ADA PARKING AND ADJACENT ACCESS AISLES SHALL HAVE A MAXIMUM SLOPE OF 2% IN ANY DIRECTION.

LEGEND

	PROPOSED 2" ASPHALT OVERLAY
	PROPOSED COLDMILL TRANSITION



CONSTRUCTION NOTES:

1. ALL WORK PERFORMED AND MATERIALS SUPPLIED SHALL CONFORM TO ODOT STANDARDS AND SPECIFICATIONS AND THE COMANCHE NATION.
2. THE CONTRACTOR SHALL OBSERVE THE EXISTING FLOW OF WATER AND PRESERVE THE NATURAL PATHS THROUGH THE PARKING LOT AREA. THE CONTRACTOR SHALL REMOVE EXCESS EARTH AND SMOOTH ELEVATION CHANGES IN AREAS THAT DO NOT HAVE AN EXISTING PAVED SURFACE, AS APPROVED BY THE INSPECTOR.
3. THE CONTRACTOR SHALL BE RESPONSIBLE FOR NOTIFYING ALL UTILITY COMPANIES AND GOVERNMENTAL AGENCIES WHO MIGHT HAVE UTILITY LINES ON OR ABOUT THE PREMISES, OR WHO MIGHT BE AFFECTED BY THE CONSTRUCTION. THE CONTRACTOR SHALL ALSO COORDINATE HIS ACTIVITIES WITH THE UTILITY COMPANIES TO ENSURE COMPLIANCE WITH THE PROJECT SCHEDULE. THE CONTRACTOR SHALL MAKE EVERY EFFORT TO LOCATE AND PROTECT EXISTING UTILITY LINES, AND SHALL REPAIR ANY DAMAGES.
4. THE CONTRACTOR SHALL BE RESPONSIBLE FOR HIS OWN CONSTRUCTION STAKING AND ELEVATION GRID SURVEY IF REQUIRED TO DRAIN THE PROJECT. COST OF CONSTRUCTION STAKING TO BE INCLUDED IN OTHER ITEMS.
5. ALL SIGNS, PAVEMENT MARKINGS, AND OTHER TRAFFIC CONTROL DEVICES SHALL CONFORM TO THE MANUAL ON UNIFORM TRAFFIC CONTROL DEVICES, LATEST EDITION.
6. THE CONTRACTOR SHALL BE RESPONSIBLE FOR HIS OWN CONSTRUCTION STAKING AND ELEVATION GRID SURVEY IF REQUIRED TO DRAIN THE PROJECT. COST OF CONSTRUCTION STAKING TO BE INCLUDED IN OTHER ITEMS.

LEGEND

 PROPOSED 3" TBSC



CONSTRUCTION NOTES:

1. ALL WORK PERFORMED AND MATERIALS SUPPLIED SHALL CONFORM TO ODOT STANDARDS AND SPECIFICATIONS AND THE COMANCHE NATION.
2. THE CONTRACTOR SHALL OBSERVE THE EXISTING FLOW OF WATER AND PRESERVE THE NATURAL PATHS THROUGH THE PARKING LOT AREA. THE CONTRACTOR SHALL REMOVE EXCESS EARTH AND SMOOTH ELEVATION CHANGES IN AREAS THAT DO NOT HAVE AN EXISTING PAVED SURFACE, AS APPROVED BY THE INSPECTOR.
3. THE CONTRACTOR SHALL BE RESPONSIBLE FOR NOTIFYING ALL UTILITY COMPANIES AND GOVERNMENTAL AGENCIES WHO MIGHT HAVE UTILITY LINES ON OR ABOUT THE PREMISES, OR WHO MIGHT BE AFFECTED BY THE CONSTRUCTION. THE CONTRACTOR SHALL ALSO COORDINATE HIS ACTIVITIES WITH THE UTILITY COMPANIES TO ENSURE COMPLIANCE WITH THE PROJECT SCHEDULE. THE CONTRACTOR SHALL MAKE EVERY EFFORT TO LOCATE AND PROTECT EXISTING UTILITY LINES, AND SHALL REPAIR ANY DAMAGES.
4. THE CONTRACTOR SHALL BE RESPONSIBLE FOR HIS OWN CONSTRUCTION STAKING AND ELEVATION GRID SURVEY IF REQUIRED TO DRAIN THE PROJECT. COST OF CONSTRUCTION STAKING TO BE INCLUDED IN OTHER ITEMS.
5. IF FULL DEPTH RECONSTRUCTION IS TO BE PERFORMED AT AREA 5 AFTER ALL REQUESTED PROCTOR AND DENSITY TESTS ARE COMPLETE, THE GROUND SHALL BE STRIPPED SEVEN INCHES (7") OF EXISTING GRAVEL OR TOPSOIL. SUBGRADE METHOD "B" SHALL BE PERFORMED AND COMPACTED TO AT LEAST 95% MAXIMUM DENSITY BEFORE PLACING FOUR INCHES(4") OF AGGREGATE BASE ATOP THE SUBGRADE AND COMPACTING TO 98% OF MAXIMUM DENSITY.
6. ALL SIGNS, PAVEMENT MARKINGS, AND OTHER TRAFFIC CONTROL DEVICES SHALL CONFORM TO THE MANUAL ON UNIFORM TRAFFIC CONTROL DEVICES, LATEST EDITION.
7. ALL PAVEMENT PAINT STRIPING SHALL BE APPLIED IN ONE COAT, FOUR (4) INCHES WIDE, WHITE, UNLESS SHOWN OTHERWISE ON THE PLANS.
8. THE CONTRACTOR SHALL SWEEP CLEAN ALL SOLID SURFACES PRIOR TO PLACING ASPHALT OVERLAY.
9. ALL PARKING BUMPERS WITHIN ADA SPACES SHALL BE PAINTED BLUE.
10. THE CONTRACTOR SHALL COORDINATE WITH TILLMAN COUNTY DISTRICT 2 COMMISSIONER LEVI KRASSER AT 580-512-6834 WHO WILL COMPLETE ANY NECESSARY BLADE PATCHING AND POT HOLE PATCHING OPERATIONS.
11. TWO CONCRETE PADS FOR TRASH DUMPSTERS SHALL BE CONSTRUCTED 8" THICK (14'X20' AND 34'X20') WITH #4 REBAR SPACED AT 12" C/C. ALL MATERIALS REQUIRED ARE TO BE INCLUDED IN PAY ITEM CLASS C CONCRETE.
12. ALL ADA PARKING AND ADJACENT ACCESS AISLES SHALL HAVE A MAXIMUM SLOPE OF 2% IN ANY DIRECTION.

LEGEND	
	PROPOSED 3" TBSC

MATCH LINE "D"



MATCH LINE "C"

MATCH LINE "E"



MATCH LINE "D"



MATCH LINE "E"

LEGEND

- PROPOSED 2" ASPHALT OVERLAY
- PROPOSED COLDMILL TRANSITION
- PROPOSED STOP BAR
- PROPOSED CROSS WALK

